

COMBINATION SOAP/PAPER WP506



448 x 148 x 164 mm

1000 ml soap, 250 paper towels

- Combination consisting of a liquid soap dispenser and a paper towel dispenser in robust, germ-reducing and easy-care stainless steel (AISI 304).
- All-stainless steel housing; all corners fully welded, visible surfaces satin finished and brushed. Further available surfaces: see below.
- Liquid soap dispenser with one-hand operated and non-drip soap pump with 1000 ml tank and pressure valve in brass.
- Tank with large, lockable refill opening.
- Designed for standard liquid soaps. Accessible for refilling through lockable, removable front panel with fall protection.
- Paper towel dispenser with deep-drawn paper removal opening for easy paper removal.
- Designed for approx. 250 standard paper towels in zigzag- or c-fold. Paper size (folded): 240-250 mm x 100-115 mm. Accessible for refilling through lockable front flap.
- Keyed alike cylinder locks in corrosion-resistant zinc die-casting.
- Wear parts and front panels can be replaced as modules.
- Installation dimensions: 450 x 150 x 154 mm
- Mounting: With four screws in wall opening through fixing holes in the side walls.
- Delivery includes fixing material and one pack of paper towels.
- Weight, including single package: 4.3 kg



Suggested text for specifications:

Combination consisting of a liquid soap dispenser and a paper towel dispenser in stainless steel (AISI 304) for flush mounting. All-stainless steel housing; all corners fully welded, visible surfaces satin finished and brushed. Liquid soap dispenser with one-hand operated and non-drip soap pump with 1000 ml tank and pressure valve in brass. Designed for standard liquid soaps. Accessible for refilling through lockable, removable front panel with fall protection. Paper towel dispenser with deep-drawn paper removal opening, filling quantity approx. 250 paper towels. Accessible for refilling through lockable front flap. Keyed alike cylinder locks in corrosion-resistant zinc die-casting. Delivery includes fixing material and one pack of paper towels.

Dimensions: 448 x 148 x 164 mm

Article No. WP506

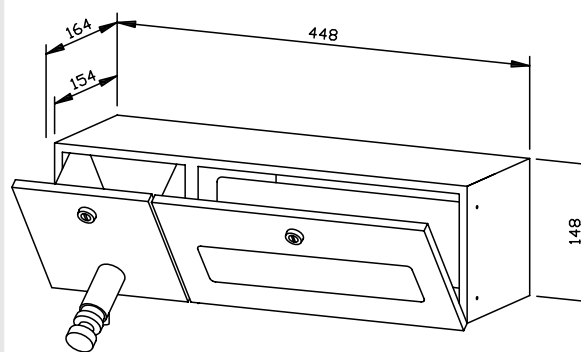

Available surfaces	ID No.
satin finished (standard)	727 613
highly polished	731 613
(coloured) plastic powder-coating	728 613

Ernst Wagner GmbH & Co. KG

Ernst-Abbe-Straße 21 · D-72770 Reutlingen · Tel.: +49712151539-0 · Fax: -20
info@wagner-ewar.de · www.wagner-ewar.de

WAGNER
EWAR